

INELCO EPLZ shown without aspiration options.

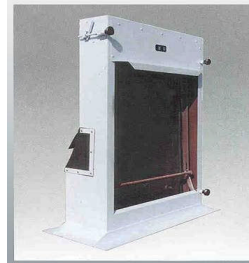

Air-Recycling Aspirator



Aspiration Channel

Application

EPLZ vibratory sieve cleaners are ideal equipment for impurities removal pre-cleaning of rice and size classification from husked rice, paddy, corn, wheat or other grains and seeds. It is also used to improve the efficiency of size grading machines, by removing tips and small particles in a previous step, thus allowing sizing equipment to work more efficiently.

INELCO machines are manufactured by ISO certified companies from Argentina, China and the USA. We back our equipment 100% with unprecedented warranty terms.



Vibro-motor

Options

Design and Features

- Rugged design, compact structure, two-screen deck design and rubber balls as the cleaning agent.
- Material feeding across the entire screen width offers high performance and efficiency.
- Two vibrating-motors provide the vibration source.
- Both inclinations of motor and screen box, as well as shock motion are adjustable for each particular application.
- Features a smooth and quiet running resulting in less power consumption and maintenance.



- Pneumatic separation can be added by installing channel or air-recycling aspirators.

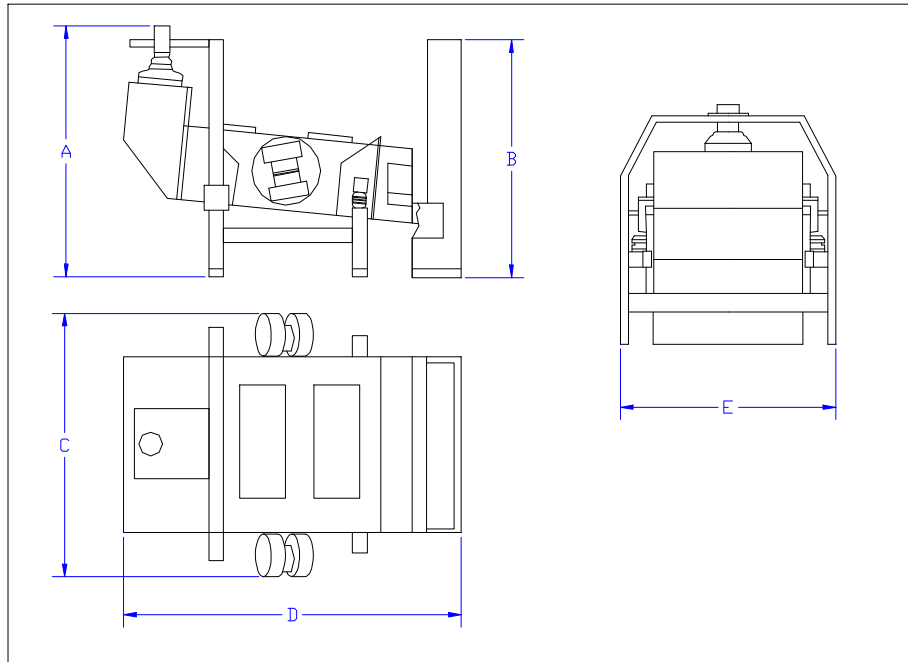

Cleaner Model	EPLZ 80	EPLZ 100	EPLZ 125
Rice Production [T/H] Paddy Pre-cleaning / Fine Cleaning	16 / 5	20 / 6	25 / 8
Power [H.P.]	2 x 1/3	2 x 1/2	2 x 3/4
Number of screen decks	2		
Screen Size [inches]	60" x 32"	60" x 40"	60" x 50"
Weight [Lbs.]	1,320	1,540	1,760
Required Aspiration [CFM] * If used with aspiration channel	1,900	2,300	3,500
Dimension A [inches]	61"		
Dimension B [inches]	85"		
Dimension C [inches]	50"	58"	68"
Dimension D [inches]	128"		
Dimension E [inches]	48"	56"	66"